

# Keysight E8257D/67D PSG Signal Generators and E8663B Analog Signal Generator Add Option UNW (Narrow Pulse Modulation 10 MHz-3.2 GHz) Kit Part Numbers: E8257DK-UNW, E8267DK-UNW, and E8663BK-UNW

Notice: This document contains references to Agilent. Please note that Agilent's Test and Measurement business has become Keysight Technologies. For more information, go to [www.keysight.com](http://www.keysight.com).

## Installation Note

Part Number: E8251-90381  
Printed in USA August 2014



E8251-90381

**Notice**

The information contained in this document is subject to change without notice.

Keysight Technologies makes no warranty of any kind with regard to this material, including but not limited to, the implied warranties of merchantability and fitness for a particular purpose. Keysight Technologies shall not be liable for errors contained herein or for incidental or consequential damages in connection with the furnishing, performance, or use of this material.

---

## Add Option UNW (Narrow Pulse Modulation 10 MHz-3.2 GHz) Kit Part Numbers: E8257DK-UNW, E8267DK-UNW, and E8663BK-UNW

Product Affected: .....	E8257D/67D and E8663B
Serial Numbers: .....	Prefix US/MY/SG4928 and lower
Options: .....	
To Be Performed By: .....	(X) Agilent Technologies Service Center (X) Personnel Qualified by Agilent Technologies (X) Customer
Estimated Installation Time: .....	2.0 hours
Estimated Verification Time: .....	2.0 hours

### Introduction

This upgrade kit adds Option UNW (Narrow Pulse Modulation) to the E8257D (Analog), E8267D (Vector) PSG Signal Generators and the E8663B Analog Signal Generator.

Installation includes the following major steps, starting on page 5:

1. Check signal generator functionality.
2. Remove the outer and inner signal generator covers.
3. Install A12 Pulse Modulator.
4. Activate Option UNW.
5. Verify proper installation of Option UNW.
6. Re-assemble the signal generator.
7. Verify signal generator calibration.

## Installation Kit Parts List

Item	Quantity	Description	Part Number
1	1	Installation Note	E8251-90381
2	2	Screw M3x0.5 8mm-LG	0515-0372
3	1	W120 Semi-Rigid Cable	E8251-20342
4	1	W76 Semi-Rigid Cable	E8251-20334
5	1	A12 Pulse Modulator	E8251-60112
6	1	Cable Retainer Base	E8251-40001
7	1	Cable Retainer Top	E8251-40007
8	1	Entitlement Certificate	5964-5143
9	1	Entitlement Certificate Envelope	5967-7169

### Tools Required

- TORX T-10 driver
- TORX T-15 driver
- TORX T-20 driver
- 5/16" open-ended wrench
- Needle-nose pliers

## Safety Considerations

---

**WARNING**            **Before you disassemble the signal generator, turn the power switch off and unplug the power cord. Failure to unplug the signal generator can result in personal injury.**

---

---

**CAUTION**            Electrostatic discharge (ESD) can damage or destroy electronic components. All work on electronic assemblies should be performed at a static-safe workstation.

---

### Check Signal Generator Functionality

Use the following procedure to confirm that the signal generator powers up and the internal check identifies no errors. The internal check evaluates the operation of the signal generator and returns an error message if it detects a problem.

---

**NOTE**            When the signal generator is first connected to ac line power, the error message **ERROR 514, Reference Oven Cold** occurs which causes both the **OVEN COLD** annunciator and the **ERR** annunciator to turn on.

After approximately five minutes, the **OVEN COLD** annunciator automatically clears, but the **ERR** annunciator remains on until all errors are cleared from the error queue.

---

1. Turn on the signal generator and let it warm up for at least five minutes.
2. Run the signal generator self-test by pressing **Utility > Instrument Info/Help Mode > Self Test > Run Complete Self Test**. Upon completion a summary of the self-test will be displayed. Use the *E8257D/67D PSG Service Guide* or *E8663B Analog Service Guide* to troubleshoot any failures detected by the test.

---

**NOTE**            Some circuits may require up to 50 minutes to warm up before passing the self-test. If self-tests continue to fail after 50 minutes of warm up, troubleshoot the instrument.

---

3. Check to see if the **ERR** annunciator is on.
  - If the **ERR** annunciator is on, review the error messages in the error queue by pressing **Utility > Error Info**. The first page of error messages in the error queue appears in the display text area. (Refer to the signal generator error messages document for information about each error message.)  
After resolving all problems causing errors, press **Clear Error Queue(s)**.
  - If the **ERR** annunciator is off, the signal generator functionality check has passed.

## **Remove the Outer and Inner Signal Generator Covers**

### **Remove the Outer Cover**

Refer to Figure 1.

1. Disconnect the power cord.
2. Using a T-20 driver, loosen the two screws (1) and remove the strap handle (2).
3. Using a T-15 driver, remove the center screws (3) on the four rear-panel feet (4).
4. Remove the four bottom feet (5) from the cover by lifting the tab and sliding the foot toward the tab.
5. Place the signal generator on its side.
6. Tilt the signal generator forward and slide the outer cover (6) back to remove it from the frame.

**Figure 1**

**Outer Cover Removal**

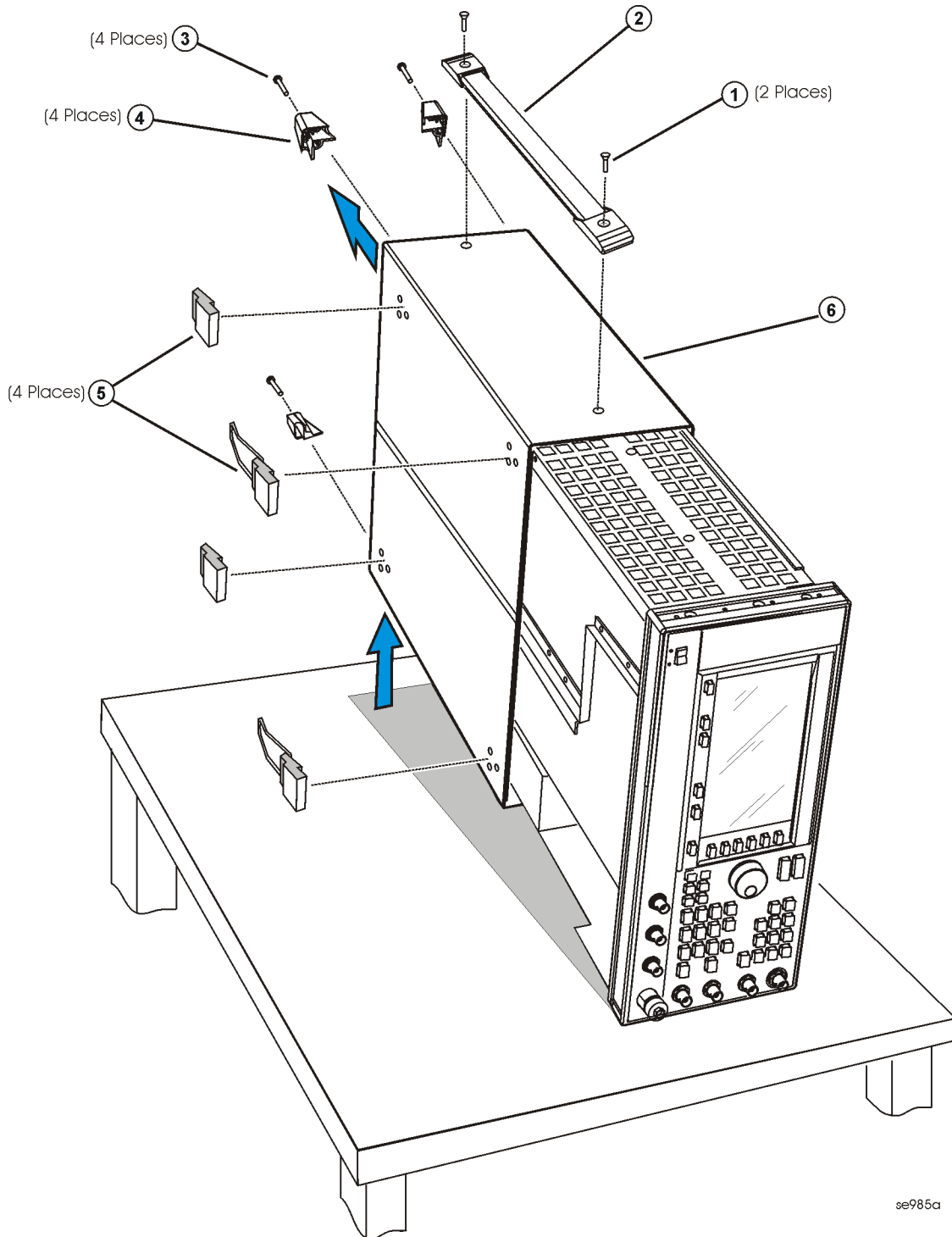

## **Remove the Inner Top Cover**

Refer to Figure 2.

1. Using a T-10 driver, remove the screws (1) from the inner-top cover (2). There are twelve screws for the E8257D & E8663B and eleven screws for the E8267D.
2. Remove the inner-top cover.



Figure 2

Inner Top Cover Removal

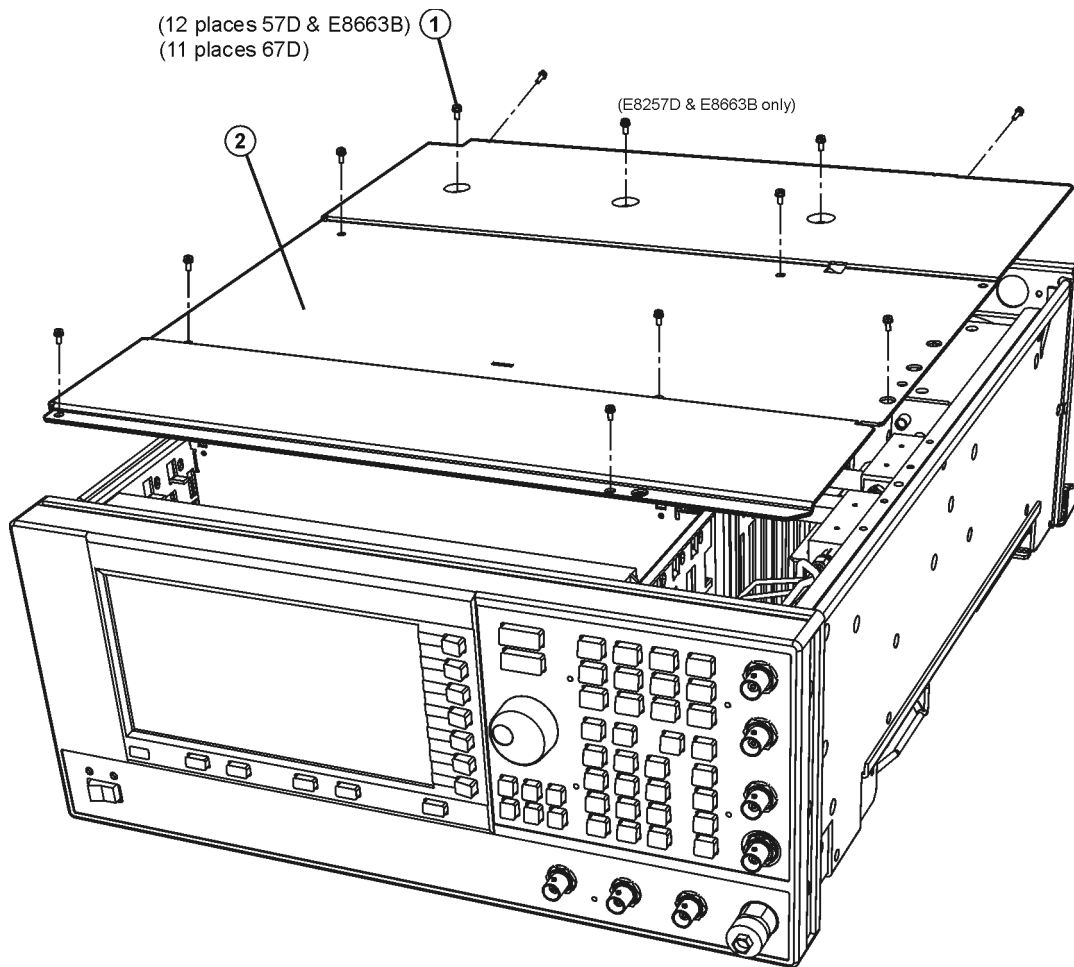

## **Install the A12 Pulse Modulator Assembly (For instruments with Option 1EH)**

Refer to Figure 3.

1. Remove the A38 Lowband Switch Filter assembly.
2. Using needle-nose pliers, remove the cable retainer base for W119 (E8251-20333, not shown).
3. With the A31 Motherboard facing you, using a 5/16" open-ended wrench, remove the other end of semi-rigid cable W119.

---

**NOTE**            W119 is connected to the A38 Lowband Switch Filter (OUT) and the A23 Lowband Coupler/Detector (IN).

---

4. Using the T-10 driver, insert two screws (1) through the A12 Pulse Modulator bracket and into the main chassis. Torque to 9 in-lbs.
5. Attach the loose end of the W69 ribbon cable (comes with the A12 Pulse Modulator assembly) to the A26 MID board, J14.
6. Install W76 (E8251-20334) from the A31 Motherboard (LB Output) to the A12 Pulse Modulator. Torque to 8 in-lbs.
7. Install semi-rigid cable W75 (E8251-20033) from the A23 Lowband Coupler/Detector to the A12 Pulse Modulator. Torque to 8 in-lbs.
8. Attach the loose end of flexible cable W16 (comes attached with the A12 Pulse Modulator assembly) to A11J204.

Figure 3

A12 Pulse Modulator Board

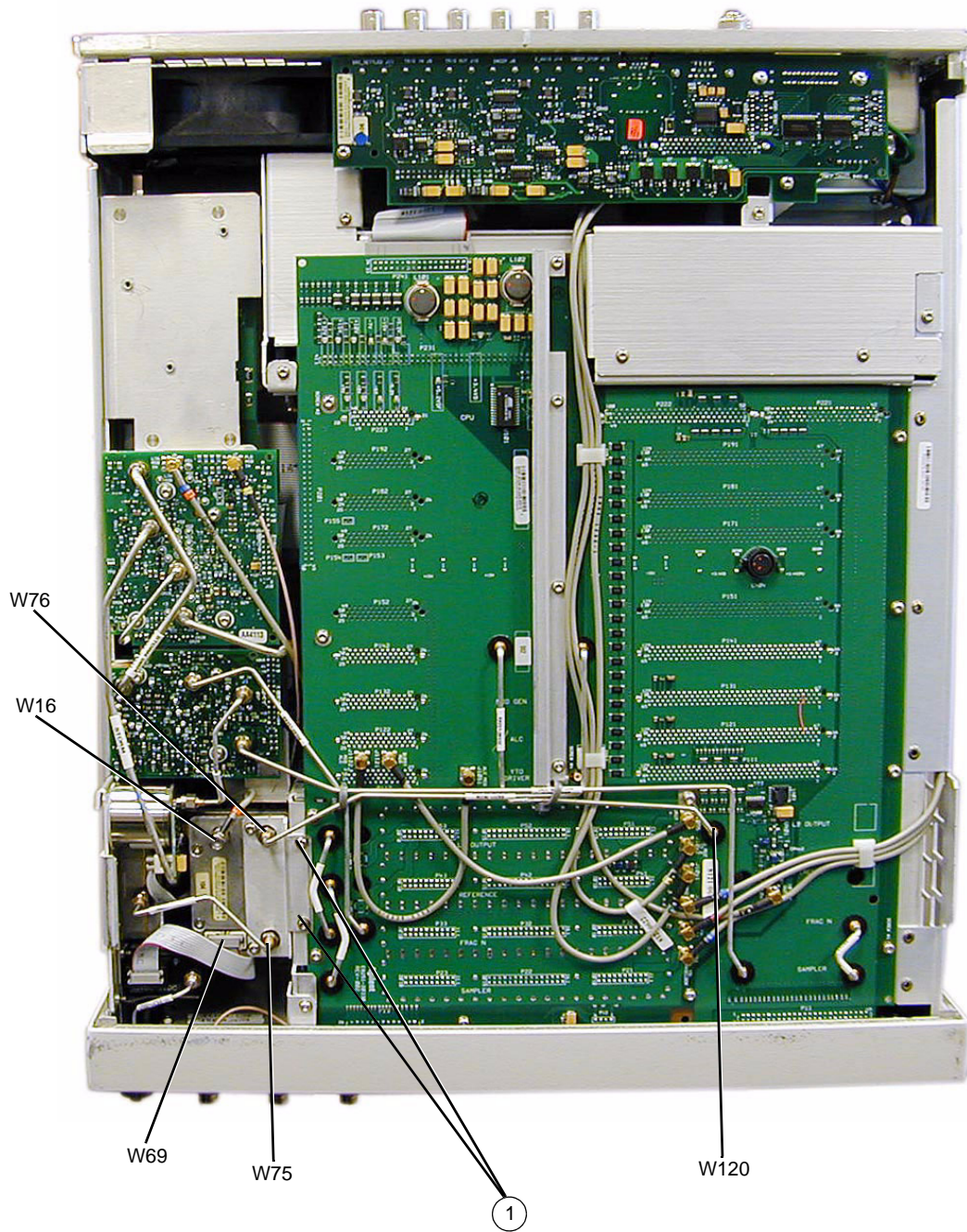

## **Install the A12 Pulse Modulator Assembly (For instruments without Option 1EH)**

Refer to Figure 4.

1. Remove A6 thru A8.
2. Using needle-nose pliers remove the cable retainer base for W37 (E8251-20225, not shown).
3. With the A31 Motherboard facing you, using a 5/16" open-ended wrench, remove the other end of semi-rigid cable W37.

---

**NOTE** W37 is connected to the A31 Motherboard (LB Output) and the A23 Lowband Coupler/Detector (IN).

---

4. Using the T-10 driver, insert two screws (1) through the A12 Pulse Modulator bracket and into the main chassis. Torque to 9 in-lbs.
5. Attach the loose end of the W69 ribbon cable (comes with the A12 Pulse Modulator assembly) to the A26 MID board, J14.
6. Install semi-rigid cable W120 (E8251-20342) from the A31 Motherboard (LB Output) to the A23 Lowband Coupler Detector. Torque to 8 in-lbs.
7. Install semi-rigid cable W75 (E8251-20033) from the A23 Lowband Coupler/Detector to the A12 Pulse Modulator. Torque to 8 in-lbs.
8. Attach the loose end of flexible cable W16 (comes attached with the A12 Pulse Modulator assembly) to A11J204.

Figure 4

A12 Pulse Modulator Board

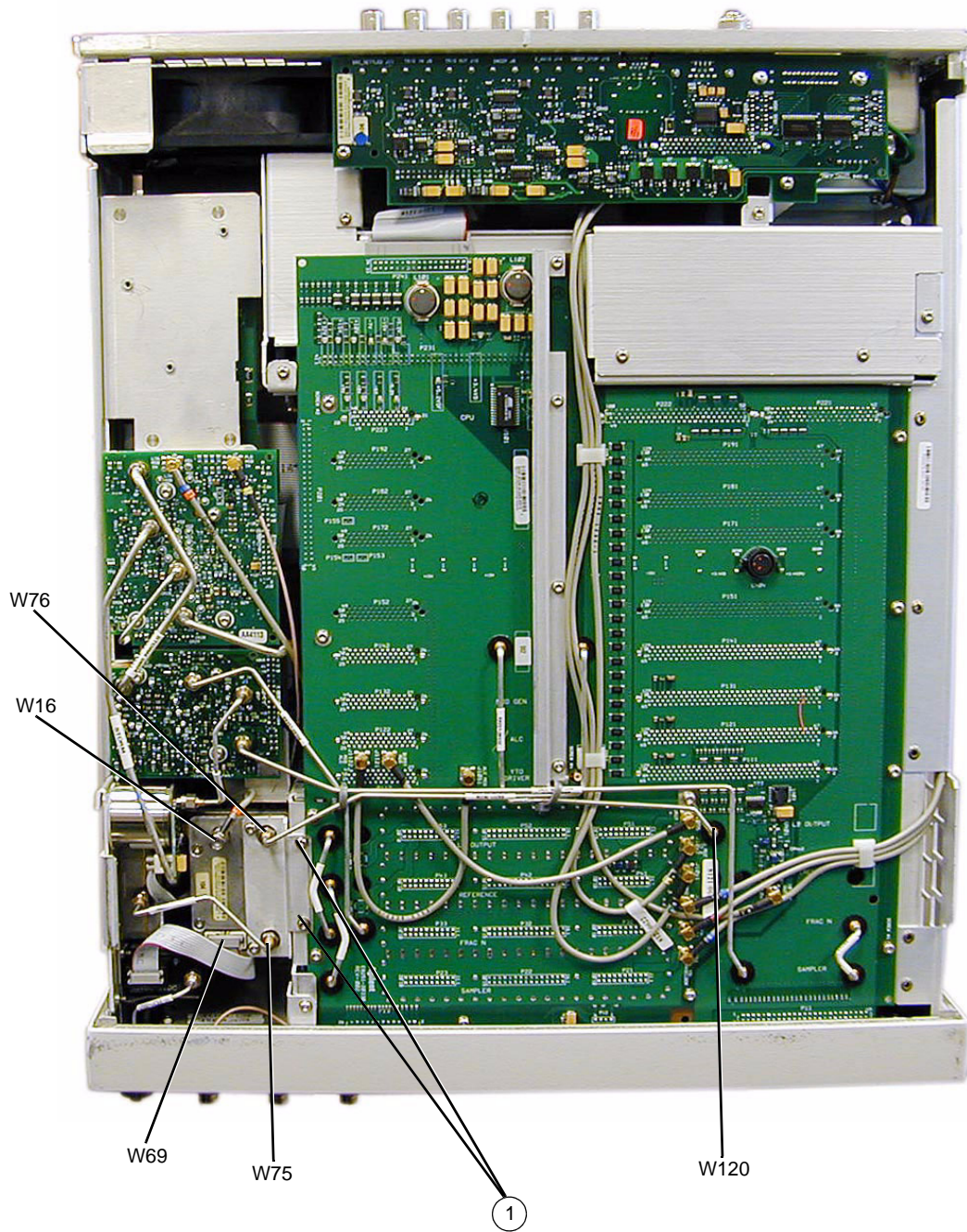

## Activate Option UNW

1. Turn the signal generator on and allow it to warm up for 5 minutes.
2. Connect the instrument to the LAN, using the instructions in the Agilent Signal Generator Programming Guide.
3. Load the IP address into the instrument, by pressing **Utility > GPIB/RS-232/LAN > LAN Setup > IP Address**. Enter the IP address.
4. Using the web browser on your PC enter the following URL, replacing <ip-address> with the actual IP address you entered into the instrument in step 3: <http://<ip-address>/update>.
5. Scroll to “Update optional PULSE MODULATOR”, select “add:E8251-60064”, enter the modulators serial number and click Execute.
6. Check Firmware Version and Update if <C.04.71
  - a. Press **Utility > Instrument Info/Help Mode > Diagnostic Info**.
  - b. If the firmware is <C.04.71, upgrade the firmware.
7. Update the Arrays
  - a. Connect the instrument to the LAN and write down the IP address.
  - b. Load the IP address into the instrument, by pressing: **Utility > GPIB/RS-232/LAN > LAN Setup > IP Address**.
  - c. Open a web browser on your PC.
  - d. Enter the following URL, replacing <ip-address> with the actual IP address of your instrument, <http://<ip-address>/update>.
  - e. Type in or, if using the web to view this installation note, copy the script from below and paste it into the text area on the update page.

```
cd "ALC FED PULSE DELAY", 0, 9
cd "ALC FED PULSE DELAY", 1, 9
cd "ALC FED PULSE DELAY", 2, 9
cd "ALC FED PULSE DELAY", 3, 9
cc "ALC FED PULSE DELAY"
cd "ALC RED PULSE DELAY", 0, 245
cd "ALC RED PULSE DELAY", 1, 180
cd "ALC RED PULSE DELAY", 2, 180
cd "ALC RED PULSE DELAY", 3, 180
cd "ALC RED PULSE DELAY", 4, 230
cd "ALC RED PULSE DELAY", 5, 190
cd "ALC RED PULSE DELAY", 6, 170
cd "ALC RED PULSE DELAY", 7, 170
cd "ALC RED PULSE DELAY", 8, 230
cd "ALC RED PULSE DELAY", 9, 190
cd "ALC RED PULSE DELAY", 10, 180
cd "ALC RED PULSE DELAY", 11, 180
cd "ALC RED PULSE DELAY", 12, 195
cd "ALC RED PULSE DELAY", 13, 180
cd "ALC RED PULSE DELAY", 14, 180
cd "ALC RED PULSE DELAY", 15, 180
cc "ALC RED PULSE DELAY"
ky 42718
```
  - f. Press Execute, to update the arrays.

- g. Cycle the instrument power.
8. Follow the instructions on the Entitlement Certificate.

### **Verify Proper Installation of Option UNW**

1. Press: **Utility > Instrument Info > Help Info > Options Info.**
2. Make sure Option UNW is listed.

---

**NOTE**            If you enable an option that does not have the required hardware installed, the menus for that option will be activated but the option *cannot* operate.

---

### **Re-Assemble the Signal Generator**

Refer to Figure 1 and Figure 2.

1. Reinstall the inner and outer instrument covers by reversing the order for removal.
2. Torque all T-10 screws to 9 in-lbs.
3. Torque all T-15 and T-20 screws to 21 in-lbs.

## Verify Signal Generator Calibration

1. Turn the signal generator on and allow it to warm up for 30 minutes.
2. Perform the following adjustment and performance tests to verify signal generator calibration. Refer to the PSG Family Signal Generators Service Software or the E8663B Analog Signal Generator Service Software:
  - ADC Calibration
  - ALC Dynamic Calibration
  - Power Flatness Calibration
  - Pulse Width Calibration
  - Self Tests
  - Internal Pulse Modulation Level Accuracy
  - Internal Pulse Modulation Rise/Fall Time
  - External Pulse Modulation ON/OFF Ratio